

AnyWireASLINK System Products Guide

ASLINKSENSOR [ASLINK Sensor] BS-K4117-M□□-1K

[Notes on Safety]

Precautions that must be observed in order to use this system safely are indicated as shown below. You must observe these precautions.

- WARNING** A WARNING indicates a potentially hazardous situation which, if not handled correctly, could result in death or serious injury.
- CAUTION** A CAUTION indicates a potentially hazardous situation which, if not handled correctly, may result in personal injury or property damage.

- WARNING**
- System Safety
This system is intended for general industrial applications. It does not have functions for supporting applications requiring higher levels of safety such as safety-related devices or accident prevention systems.
 - Always turn off the system power before attempting to mount or replace.
 - Prolonged continuous flow of a rated load current or higher or a transit current due to load short-circuit or similar problem, in the hybrid unit including the output unit and the output circuit may result in smoke generation or fire. An external safety device such as a fuse must be installed.

- CAUTION**
- System power supply
Use a stabilized 24V DC power supply. Use of a non-stabilized power supply may cause problems with the system.
 - Separately route high-voltage and power cables
Although the AnyWireASLINK has a high noise margin, lay the transmission lines and I/O cables so as to keep them away from high-voltage and power cables.
 - Connectors and terminals
 - Pay careful attention to the length and installation of cable wiring to ensure that connectors and cables are neither stressed nor disconnected even if they are stressed.
 - Make sure to prevent any metal objects from getting inside the connectors or the terminal blocks.
 - Short-circuits caused by metal objects or mis-wiring are likely to damage the device.
 - Do not impose any external loads on the units.
Doing so may cause a failure.
 - Do not disconnect or reconnect between the transmission line and slave units when a transmission line is operating.
A malfunction may occur.
 - Use the AnyWireASLINK within the range of the specifications and conditions shown below.

[Warranty]

- Warranty period
The warranty on the delivered Product shall continue to be effective for one (1) year after the delivery thereof to a location as designated by the original owner.
- Scope of warranty
Should a defect occur in any part of the Product during the foregoing warranty period when it is used normally in accordance with the specifications described in this User's Manual, the Company shall replace or repair the defect free of charge, except when it arises as a result of:
 - [1] Misuse or abuse of the Product by the owner;
 - [2] Fault caused by cause other than the delivered Product;
 - [3] Unauthorized modification or repair of the Product by any party other than the Company;
 - [4] Any unusual force of nature, disaster, or other cause beyond the Company's control.

The term "warranty," as used herein, refers to the warranty applicable to the delivered product alone. The Company shall not be liable for any damages consequential or incidental to a malfunction of the delivered product.
- Repair at cost
After the expiration of the warranty period, any troubleshooting or repairs shall be done at the expense of the owner.
Even during the warranty term, any repairs and troubleshooting for defects arising from causes outside the scope of the warranty as specified above shall be done at the owner's expense.

[Type]

AnyWireASLINK proximity sensor: Amplifier-embodied type, all metal detection type

BS-K4117-M12-1K	M12, black nickel plating
BS-K4117-M18-1K	M18, black nickel plating
BS-K4117-M30-1K	M30, black nickel plating

[Function]

Model	ASLINKSENSOR two-wire (non-isolated) terminal
Detection method	Electromagnetic induction type
Functions	Sensitivity adjustment value (Threshold)
	Hysteresis
	Alarm judgment value
	Alarm judgment time
	Normally open/Normally close
	Delay timer
	Slave unit voltage drop
	Sensing level drop
	Teaching abnormality

[Included items]

BS-K4117-M12-1K	This product...1
BS-K4117-M18-1K	Nut...2
BS-K4117-M30-1K	Toothed washer...1

- * If mounting clamps are required, please purchase them separately.
- * Setting of addresses in this product requires the "address writer ARW-04 (Ver.04-1.01 or higher) or ARW-03 (Ver.2.10 or higher)." Prepare that as well.

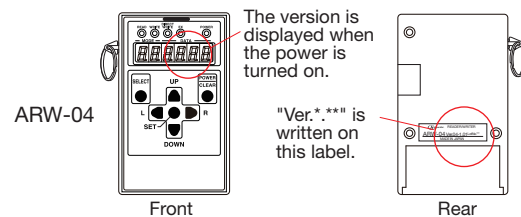

[Name of each part]

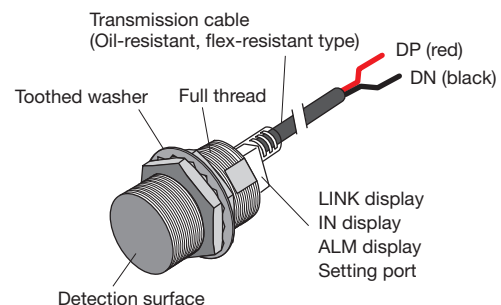

Example for BS-K4117-M18-1K

[How to connect AnyWireASLINK]

You can select use of either a two-wire or four-wire terminal for the AnyWireASLINK according to the load current.

This Products Guide describes a two-wire (non-isolated) terminal.

If the load current is small, using a two-wire (non-isolated) terminal allows for achieving simplified wiring without a local power supply.

If you are prioritizing the sites of concentrated loads or the number of units connected, hybridization with a four-wire (isolated) terminal, which supports local power supply, is also possible.

Make sure to use a four-wire (isolated) terminal in the case of input and load driving using an external power supply.

In the case of hybridization, refer to the Four-Wire (Isolated) Terminal Products Guide separately.

[Connection Example]

■ Connection example using a two-wire (non-isolated) terminal

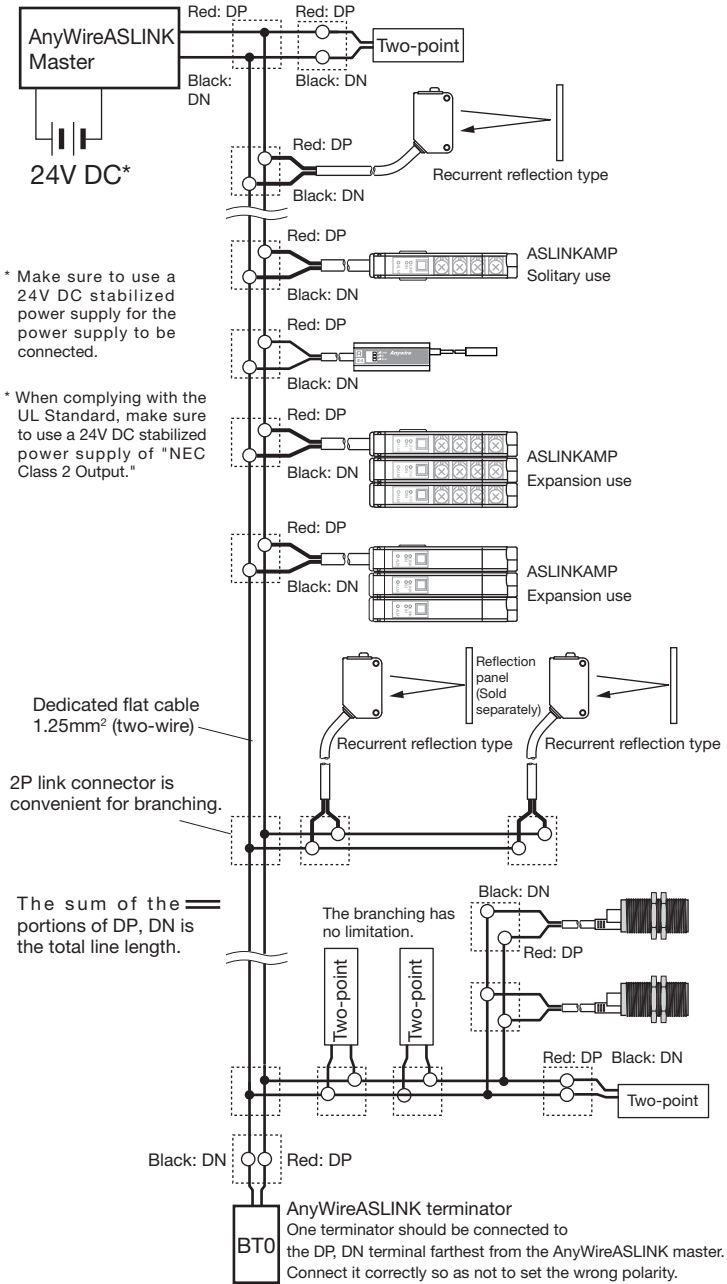

■ Relationship between the size and length of the transmission line and the supply current (Table 1)

Size of the transmission line (DP, DN)	Supply current on the transmission line (DP, DN)		
	Total length 50m or less	Total length: Over 50m, no longer than 100m	Total length: Over 100m, no longer than 200m
1.25mm ²	MAX 2A	MAX 1A	MAX 0.5A
0.75mm ²	MAX 1.2A	MAX 0.6A	MAX 0.3A
0.5mm ²	MAX 0.8A	MAX 0.4A	MAX 0.2A



- Refer to Table 1 so that the size and length of the transmission line and the allowable supply current lie within an appropriate range.

- Connect the same symbols (DP, DN) correctly between the AnyWireASLINK master and each device.
- The branching length and branch number have no limitations.
- Include the length of the cable provided with the terminal in the "total line length."
- Connect the terminator "BT0 (polar)" to the terminal on the transmission line farthest from the AnyWireASLINK master.

■ Example of mixture of two-wire (non-isolated) and four-wire (isolated) terminals

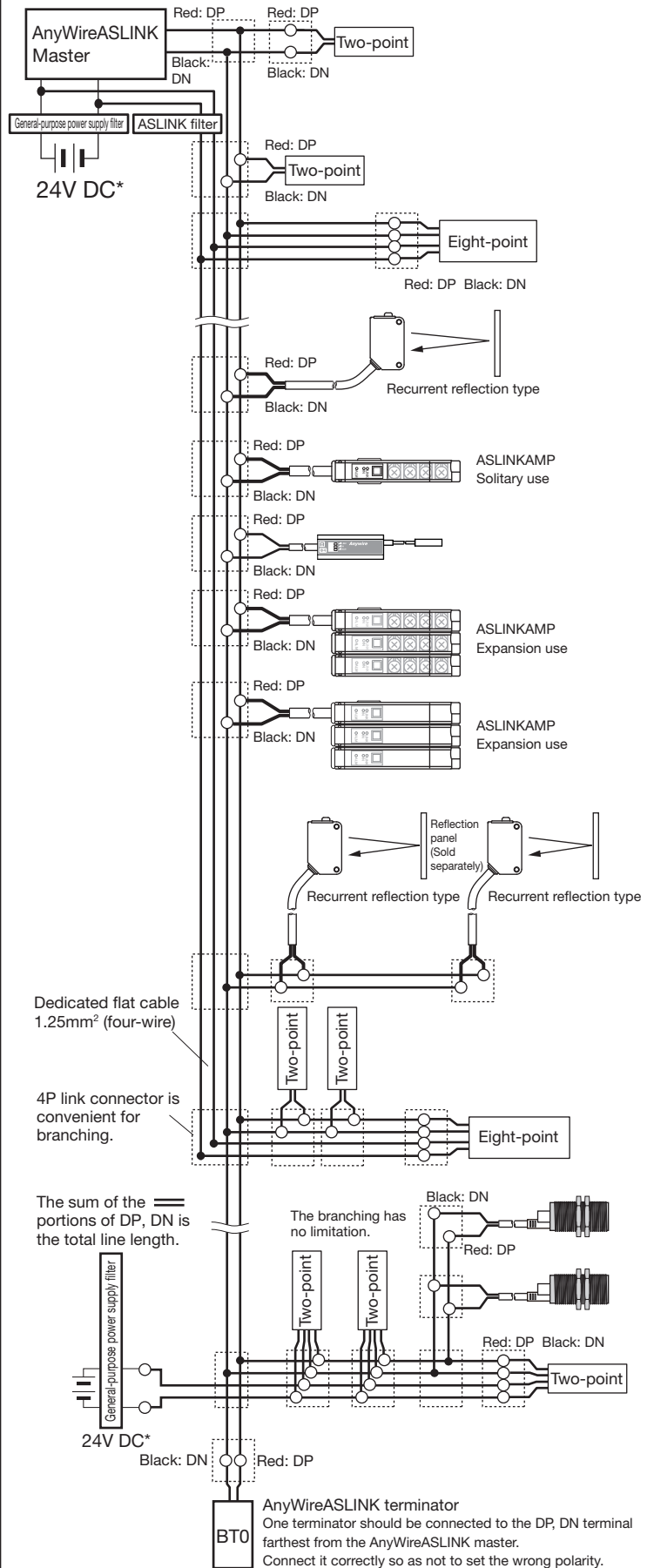

Make sure to use a four-wire (isolated) terminal if connecting to a load (e.g. input/output port) controlled by a different power supply than that used in the AnyWireASLINK. Otherwise, a malfunction may occur.

[Notes on Combined Use with Four-Wire (Isolated) Terminals]

If any of the side-by-side lines of DP, DN, 24V, or 0V exceeds the total length of 50m in a power supply system to be supplied, serially connect the "ASLINK filter [Type ANF-01]" or a "filter of COSEL Co., Ltd. [Type EAC-06-472]" to 24V and 0V in the starting position of the side-by-side lines.

This will improve noise resistance, reduce the impact of crosstalk by transmission signals, and stabilize the signals.

Insert a filter whether using a master power supply for the entire system or using a local power supply.

Insert the "ASLINK filter [Type ANF-01]" regardless of installation method and distance when complying with CE Standard.

Filter allowable power current

Model	Type	Allowable power current
ASLINK filter	ANF-01	MAX 5A/24V DC
Filter of COSEL Co., Ltd.	EAC-06-472	MAX 6A/24V DC

AnyWire Type: ANF-01 Connection example

(The figure is an explanatory schematic.)

Adjust the actual terminal layout to meet each device.

① Power supply to the entire system

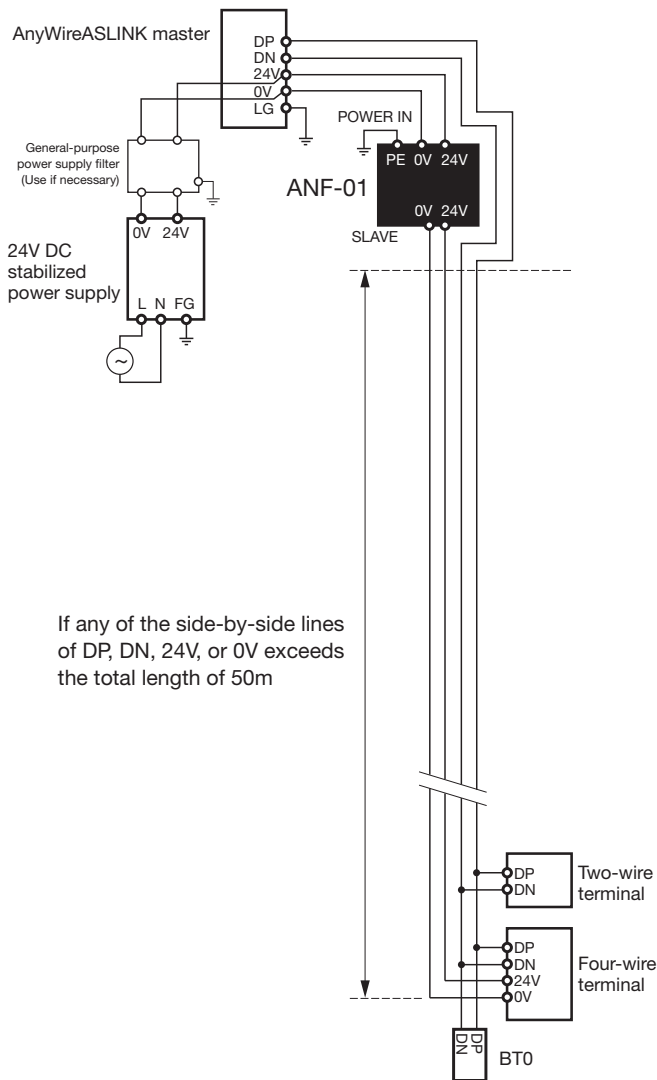

② Local power supply/branching

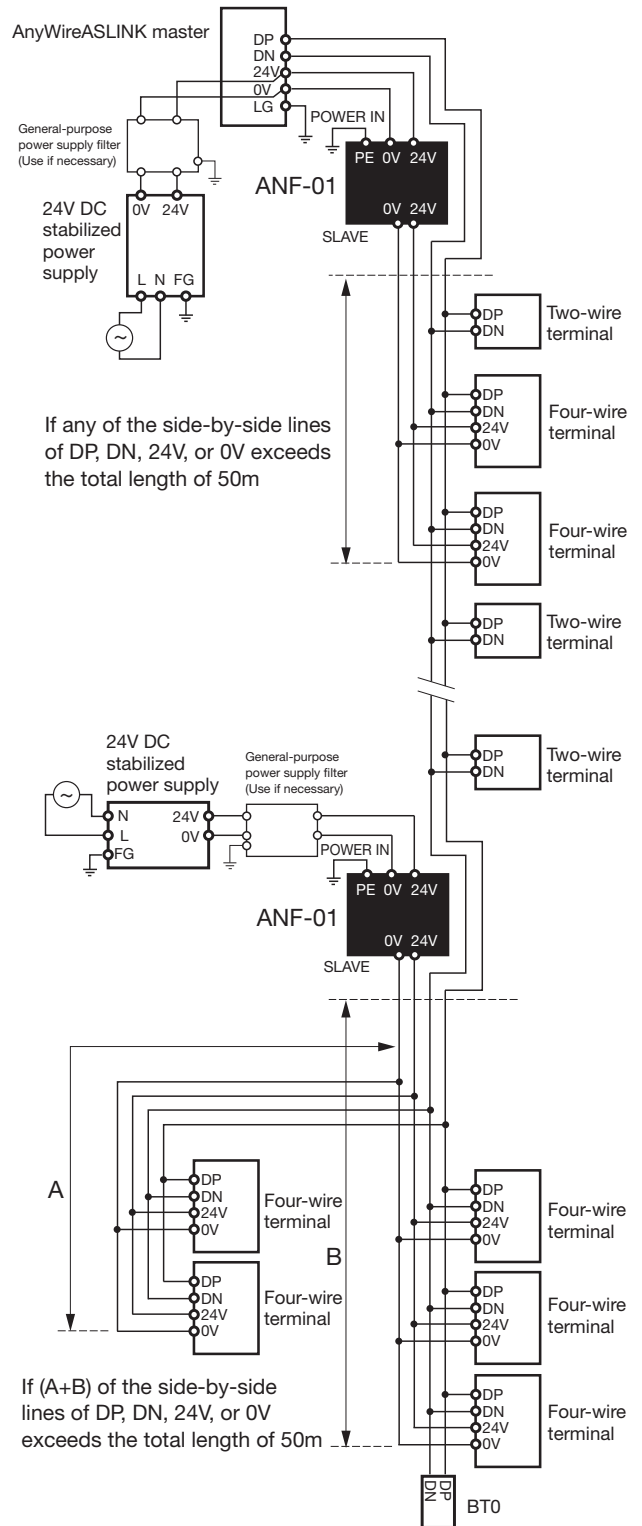

■ COSEL Co., Ltd. Type: EAC-06-472 Connection example

(The figure is an explanatory schematic.
Adjust the actual terminal layout to meet each device.)

① Power supply to the entire system -----

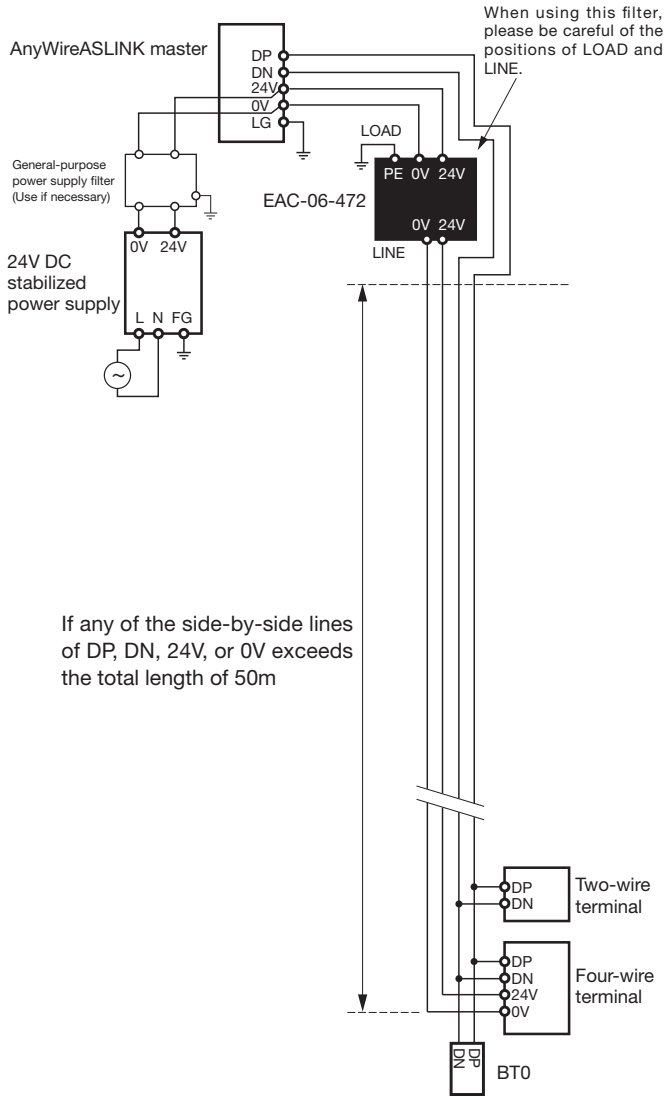

② Local power supply/branching -----

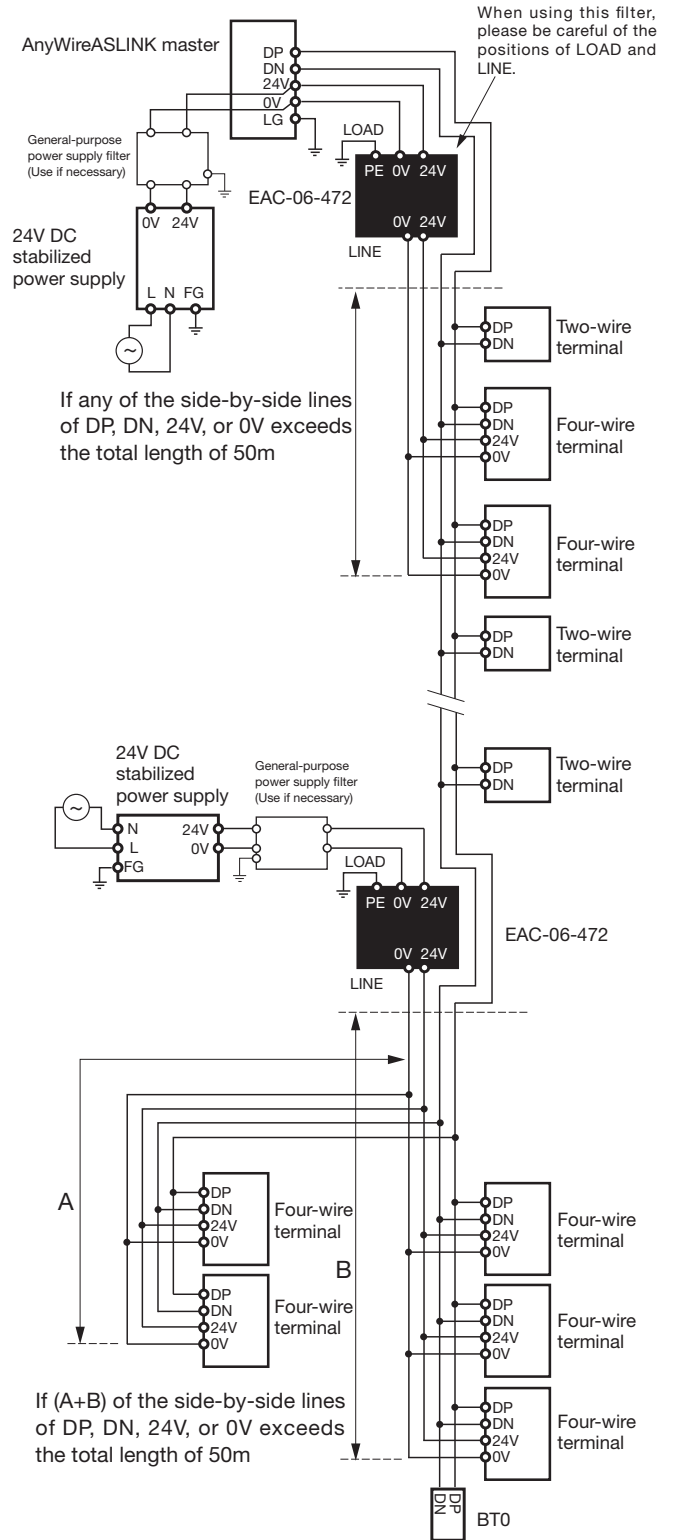

[How to connect]

Connect to the AnyWireASLINK transmission line (DP, DN).
DP and DN have polarity, so be sure to connect correctly.

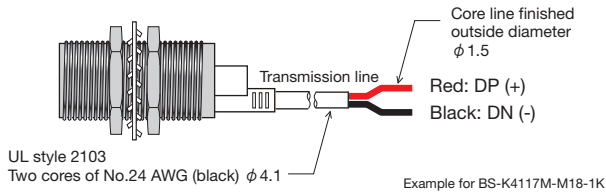

■ Example of mounting an LP connector to the end of the transmission line

Applicable LP connector: LP2-PWH-10P (2P), LP4-WW-10P (4P)

* The following explanatory figure is an example for the LP2-PWH-10P.

Place the lines in the groove so that the black line (DN) is positioned nearer the hinge side (pin 1) of the cover, and fold part A onto the part B side, and then hitch the hook C to fix the cover.

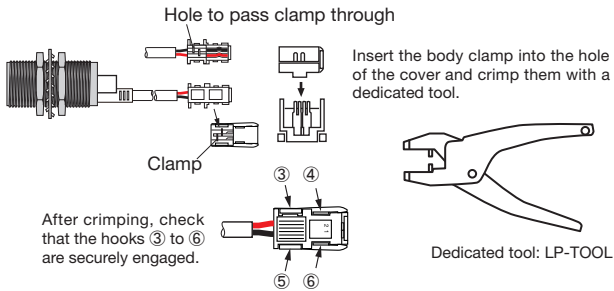
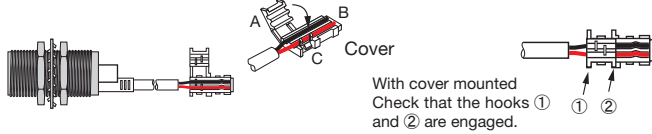

For the LP4-WW-10P, perform crimping with pin 1 for DN, pin 2 for DP, and pins 3 and 4 empty.

[Installation Examples]

If you expect you will change the settings, install the unit so that the setting port is visible.

<BS-K4117-M12-1K>

- Installation hole radius

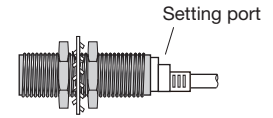
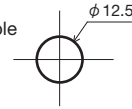

Use the toothed washer when affixing.
Tightening torque: 5.9N·m

<BS-K4117-M18-1K>

- Installation hole radius

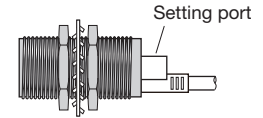
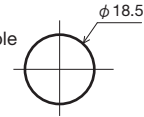

Use the toothed washer when affixing.
Tightening torque: 15N·m

<BS-K4117-M30-1K>

- Installation hole radius

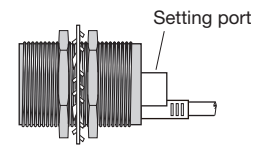
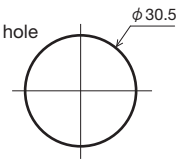

Use the toothed washer when affixing.
Tightening torque: 59N·m

CAUTION

When affixing this product, provide enough slack so that cables and connection connectors are not stressed.
Do not over-tighten screws. Doing so may cause a failure.

[Installation Location]

- Location where this product is not directly subject to vibration or shock
- Location without condensation
- Location where the atmosphere is free of corrosive gas, flammable gas, and sulfur
- Location far from high-voltage or high-current cables
- Location far from cables and controllers that generate servo, inverter, or other high-frequency noise
- Location away from direct sunlight

[Precautions for Use]

- This unit is to be used connected to an AnyWireASLINK transmission line. It will not operate if it is directly connected to the sequence I/O card or the like.
- Use with an appropriate voltage range.
- Include the transmission line provided with this product in the total line length.

[Various settings]

Item

Address number setting Teaching Parameter setting

Common procedure for address writer operation

Be sure to connect to the AnyWireASLINK master unit to use. An address writer ARW-04 (Ver.04-1.01 or higher) or ARW-03 (Ver.2.10 or higher) is required for operation. For details about the operation method, refer to the address writer's Products Guide.

1. Connect the AnyWireASLINK slave to the AnyWireASLINK master unit. Set with the address writer while supplying transmission signals (DP, DN).

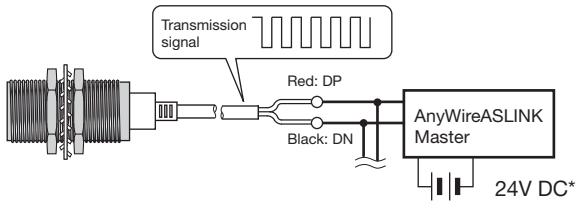

* Make sure to use a 24V DC stabilized power supply for the power supply to be connected.

2. Setting is required for all AnyWireASLINK devices. Direct the address writer toward the setting port (Fig. 2) of this product. (Bring the emitter as close as possible to the setting port.)

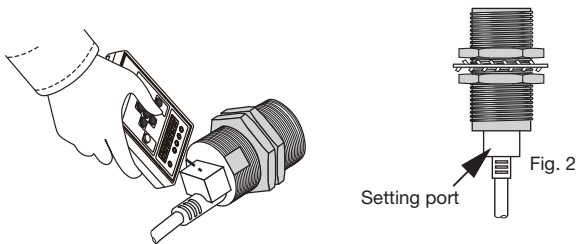

* When setting is changed in the [WRITE] mode, the setting is reflected after the system is re-started up. When setting is changed in the [DIRECT WRITE] mode, the setting is reflected at the time when the writing is completed.

* If this unit is included in a parallel arrangement, use the remote head (ARW-RH) together, and ensure that writing is not performed to terminals not intended.

Address number setting

The address number is used to set which number of the transmission frame to start with for the terminal to occupy. Set the address number in a range from "0" to "254."

CAUTION

The default address-number setting of the terminal is "255," which means no setting. If the address number setting is "255," the terminal cannot perform input/output operations. Make sure to use the terminal after setting the address number within the range of "0 to 254."

Teaching

Store the status when a work is present and when a work is absent in the ASLINKSENSOR.

[SET ON setting]

Set with detected metal present.

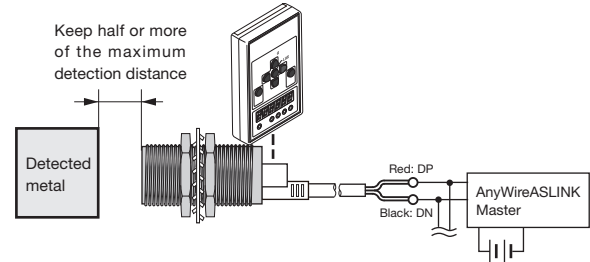

[SET OFF setting]

Set with detected metal absent.

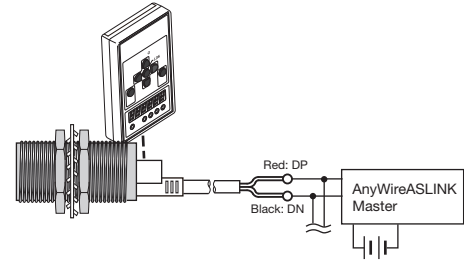

- Carry out setting with the work actually used. Maintain 50% or more of the maximum detection distance while performing settings.
- When the difference between the with/without a workpiece statuses is insufficient, ALM flashes to let you know the status. Perform setting again.

Parameter setting

Setting of threshold

Set the threshold of the sensing level to judge presence/absence of detection. * Difference in the detection state stored in teaching is 100%.

- Address writer (ARW-04, ARW-03): Parameter 01

Variable	Unit
0 - 100	%

Default: BS-K4117-M12-1K : 18
BS-K4117-M18-1K : 24
BS-K4117-M30-1K : 26

Setting of hysteresis

Set change amount of sensing required to turn detection state ON to OFF after turning the detection state OFF to ON.

- Address writer (ARW-04, ARW-03): Parameter 02

Variable	Unit
0 - 100	%

Default: 5

Alarm value Hi setting

Set an upper limit for the alarm judgment value.

- Address writer (ARW-04, ARW-03): Parameter 03

Variable	Unit
0 - 100	%

Default: 80

* Set the alarm values so that Hi is greater than Lo.

Alarm value Lo setting

Set a lower limit for the alarm judgment value.

- Address writer (ARW-04, ARW-03): Parameter 04

Variable	Unit
0 - 100	%

Default: BS-K4117-M12-1K : 19
BS-K4117-M18-1K : 25
BS-K4117-M30-1K : 27

* Set the alarm values so that Hi is greater than Lo.

Alarm value monitor time setting

Set a monitor time for the alarm judgment value.

- Address writer (ARW-04, ARW-03): Parameter 05

Variable	Unit
3 - 255	100ms

Default: 50

Normally open/Normally close setting

Set the normally open/normally close.

- Address writer (ARW-04, ARW-03): Parameter 06

Variable	Details	
0	Normally open	ON with work present
1	Normally close	ON with work absent

Default: 0

Setting for operation mode change

Set if there is an alarm diagnosis function.

- Address writer (ARW-04, ARW-03): Parameter 07

Variable	Details	
0	Simple mode	Alarm diagnosis function disabled
1	Normal mode	Alarm diagnosis function enabled

Default: 0

Setting for delay timer ON/OFF

Set the ON delay timer/OFF delay timer.

- Address writer (ARW-04, ARW-03): Parameter 10

Variable	Details	
0	No delay timer	Delay timer disabled
1	ON delay timer	ON delay timer enabled
2	OFF delay timer	OFF delay timer enabled
3	ON/OFF delay timer	ON/OFF delay timer enabled

Default: 0

Setting for delay timer value

If you set the delay timer in parameter 10, you can set the delay time.

- Address writer (ARW-04, ARW-03): Parameter 11

Variable	Unit
0 - 255	10ms

Default: 0



Parameters [08, 09, 12 to 19] are items related to internal settings. Do not perform settings.

[Monitor display]

Displays the operation status of this product using the LEDs.

Normal state: LINK flashing, ALM off, IN ON on/OFF off

Name	Indication status	Details
LINK (Green)	On	Transmission signal error
	Flashing	Transmission signal is appropriately supplied
	Off	No transmission signal
ALM (Red)	On	Sensing level drop*
	Flashing (On for 0.2 seconds, off for 1.0 second)	Slave unit voltage drop
	Flashing (0.1 seconds alternately)	Teaching abnormality
	Off	Normal
LINK ALM	Alternate flashing LINK ALM	When the master unit found that the ID (address) of this unit is duplicate or is not set.
IN (Orange)	On	ON
	Off	OFF

* Only when alarm diagnosis function is enabled

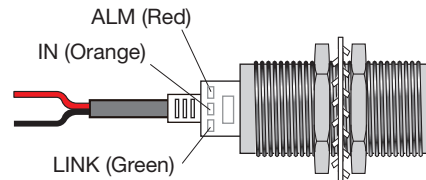

[Troubleshooting]

If the followings are displayed on the LEDs of this product, take measures as shown below.

LINK	IN	ALM	Cause	Measures
○ Off	○ Off	○ Off	- ASLINKSENSOR is not connected to an AnyWireASLINK system. - Power supply for the AnyWireASLINK system itself is not turned on.	- Confirm that there is no disconnection between the ASLINKSENSOR and the AnyWireASLINK system, and recover the connection. - Confirm the power status of the AnyWireASLINK system, and turn on the power.
● On	○ Off	○ Off	- Directly connected to 24-0V power supply.	- Re-connect to the AnyWireASLINK system.
⊙ Flashing (0.5 seconds alternately)	○ Off	⊙ Flashing (0.5 seconds alternately)	- The ASLINKSENSOR maintains the address number 255 (default setting). - The ASLINKSENSOR has an address redundant with another unit.	- Set any address number other than 255. - Look for the other unit which has the same error indication, and set any address number different from it.
—	—	⊙ Flashing (On for 0.2 seconds, off for 1.0 seconds)	- Transmission signal level reduction has been detected.	- Decrease the number of units connected to the same AnyWireASLINK system. - Shorten the transmission line between the ASLINKSENSOR and the master unit.
⊙ Flashing	—	● On	- The sensing level has been reduced.	- Confirm the ASLINKSENSOR status, adjust the position, and clean the detection surface.
⊙ Flashing	—	⊙ Flashing (0.1 seconds alternately)	- Teaching is not normally operated.	- Make sure to perform teaching operation again.

When the following error is indicated on the address writer, take measures as shown below.

Indication	Cause	Measures
[E-0303]	The set parameter is incorrect.	Check the parameter and set the correct parameter.

Take measures as follows in the following case.

Symptom	Measures
Detection cannot be performed.	- Is the detected metal in the appropriate location? → Make adjustments so that the detected metal is within an appropriate range from the ASLINKSENSOR detection surface. - Is wiring correct? → Confirm that the ASLINKSENSOR transmission line is correctly connected to the AnyWireASLINK transmission line (DP, DN). - Are the AnyWireASLINK master unit and slave unit powered by a power supply with the appropriate capacity? → Confirm the power supply. - Did you perform teaching? → Perform teaching settings with the work that is actually detected. - Are you using within the rated detection range? → Use within the rated range.
Setting cannot be performed with the address writer.	- Is wiring correct? → Reconfirm the ASLINKSENSOR transmission line connection. - Is power fed to the AnyWireASLINK system? → Confirm the power supply. - Is the set parameter correct? → Check the parameter and set the correct parameter.

[Parameters and items]

Parameter	Variable	Details	Default variable
[01.] Threshold	0 - 100%	Set the threshold of the sensing level to judge presence/absence of detection.	M12 : 18 M18 : 24 M30 : 26
[02.] Hysteresis	0 - 100%	Set change amount of sensing level required to turn detection state ON to OFF.	5
[03.] Alarm value Hi	0 - 100%	Set an upper limit for the alarm judgment value.	80
[04.] Alarm value Lo	0 - 100%	Set a lower limit for the alarm judgment value.	M12 : 19 M18 : 25 M30 : 27
[05.] Alarm value monitor time	3-255	Set a monitor time for the alarm judgment value. (1 = 100ms)	50
[06.] Normally open/ Normally close	0 1	Normally open Normally close	0
[07.] Operation mode	0 1	Simple mode Normal mode	0
[10.] Delay timer ON/OFF	0 1 2 3	Delay timer disabled ON delay timer OFF delay timer ON/OFF delay timer	0
[11.] Delay timer value	0 - 255	Set the delay time. (1 = 10ms)	0

[Specifications]

■ General Specifications

Ambient temperature/humidity for use	-10 - 60°C, 10 - 90%RH (No condensation)
Ambient temperature/humidity for storage	-25 - 75°C, 10 - 90%RH (No condensation)
Atmosphere for use	No corrosive gas
Altitude of use *1	0 to 2000m
Pollution level *2	2 or less

*1 Do not use or store the AnyWireASLINK device in an environment pressurized equal to or higher than the atmospheric pressure at an altitude of 0m. Doing so could cause a malfunction.

*2 Index that indicates the occurrence of conductive material in the environment where the device is used.
Contamination level 2 indicates that only non-conductive contamination occurs. However, incidental condensation could create temporary conductivity in this environment.

■ Transmission specifications

Power supply voltage for use	Voltage 24V DC +15% to -10% (21.6 to 27.6V DC) Ripple of 0.5Vp-p max.
Transmission method	DC power supply superimposed total frame/cyclic method
Synchronization method	Frame/bit synchronization method
Transmission procedure	Dedicated protocol
Connection mode	Bus type (Multi-drop method, T-branch method, Tree branch method)
Number of connection points	512 max. (IN: 256, OUT: 256)
Number of units connected	Up to 128 units
RAS feature	Transmission line disconnection detection, transmission line short-circuit detection, transmission power supply reduction detection, ID redundancy, ID not set detection

■ Individual specifications

Number of occupied points	One-point input	
Consumption current	Supplied via AnyWireASLINK transmission signal (DP, DN)	
	M12: 13mA	M30: 13mA
	M18: 13mA	
Detection method	Electromagnetic induction detection	
Shield presence/absence	Shield type	
Detection target *3	Non-magnetic metal/Magnetic metal	
Standard detection objects	M12: Aluminum 12×12×3mm	M30: Aluminum 30×30×3mm
	M18: Aluminum 18×18×3mm	
Detection distance (At ambient temperature of 23°C)	M12: 2mm (max.)	M30: 10mm (max.)
	M18: 5mm (max.)	
Stable detection distance	M12: 0 to 1.6mm	M30: 0 to 9.0mm
	M18: 0 to 4.5mm	
Hysteresis	Depends on parameter setting	
Response time *4	Max. 10ms	
Impact from temperature	Detection distance at 23°C	
	M12: Within ±20%	M30: Within ±10%
	M18: Within ±10%	
Impact from voltage	Within ±1% of the detection distance with the AnyWireASLINK master supplied power voltage within range of 27.6 to 21.6V	
Protective structure	IP67	
Mass (This product/Cable)	M12: Approx. 37g	M30: Approx. 105g
	M18: Approx. 49g	
Mass (Nuts/Washer)	M12: Approx. 8g	M30: Approx. 41g
	M18: Approx. 19g	

*3 The detection distance depends on the material.

*4 Time from when ON or OFF is detected until the transmission signal is transmitted. The time combining this time and the transmission 2 cycle time is the transmission delay time.

[Outside Dimensions]

Unit: mm

BS-K4117-M12-1K

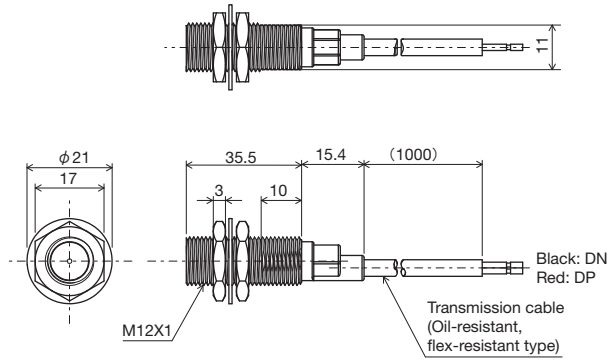

BS-K4117-M18-1K

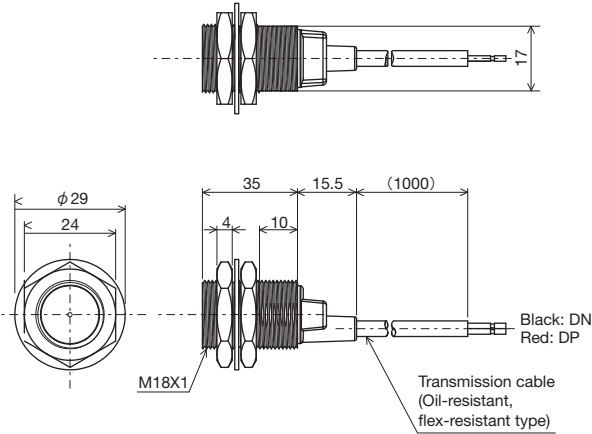

BS-K4117-M30-1K

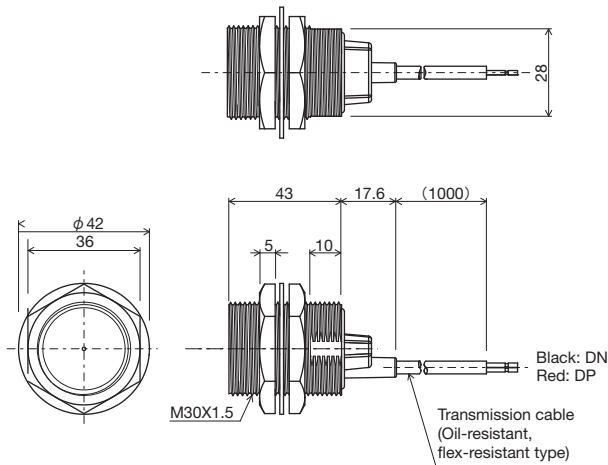

【中国版RoHS指令】

电子信息产品上所示标记是依据SJ/T11364-2006规定,按照电子信息产品污染控制标识要求制定。
本产品的环保使用期限为10年,如果遵守产品说明书中的操作条件使用电子信息产品,不会发生因产品中的有害物质泄漏或突变而引起严重的环境污染、人身事故,或损坏财产等情况。

的产品中有害物质的名称及含量

部件名称	有害物质					
	铅 (Pb)	汞 (Hg)	镉 (Cd)	六价铬 [Cr (VI)]	多溴联苯 (PBB)	多溴二苯醚 (PBDE)
安装基板	×	○	○	○	○	○
框架	○	○	○	○	○	○

本表格依据SJ/T11364的规定编制。
○: 表示该有害物质在该部件所有均质材料中的含量均在GB/T26572规定的限量要求以下。
×: 表示该有害物质至少在该部件的某一均质材料中的含量超出GB/T26572规定的限量要求。



[Address]

Anywire Anywire Corporation

Headquarters :1 Babazusho, Nagaokakyo-shi, Kyoto 617-8550 JAPAN

Contact :Contact by mail info_e@anywire.jp

:Contact by website http://www.anywire.jp